

11176 / 247417 02-06 MINI COOPER HATCHBACK (except S)

12/6/2007

GROSS LOAD CAPACITY WHEN USED AS A WEIGHT CARRYING HITCH: 1000 LBS. TRAILER WEIGHT & 100 LBS. TONGUE WEIGHT.
*****DO NOT EXCEED VEHICLE MANUFACTURER'S RECOMMENDED TOWING CAPACITY.*****

Parts List			
ITEM	QTY	PART NUMBER	DESCRIPTION
1	4	7-16 x 1 1-2 C'SUNK SOCKET SCREW	FLAT HEAD C'SUNK CAP SCREW
13	2	CM-11176-WNP	WELD NUT PLATE

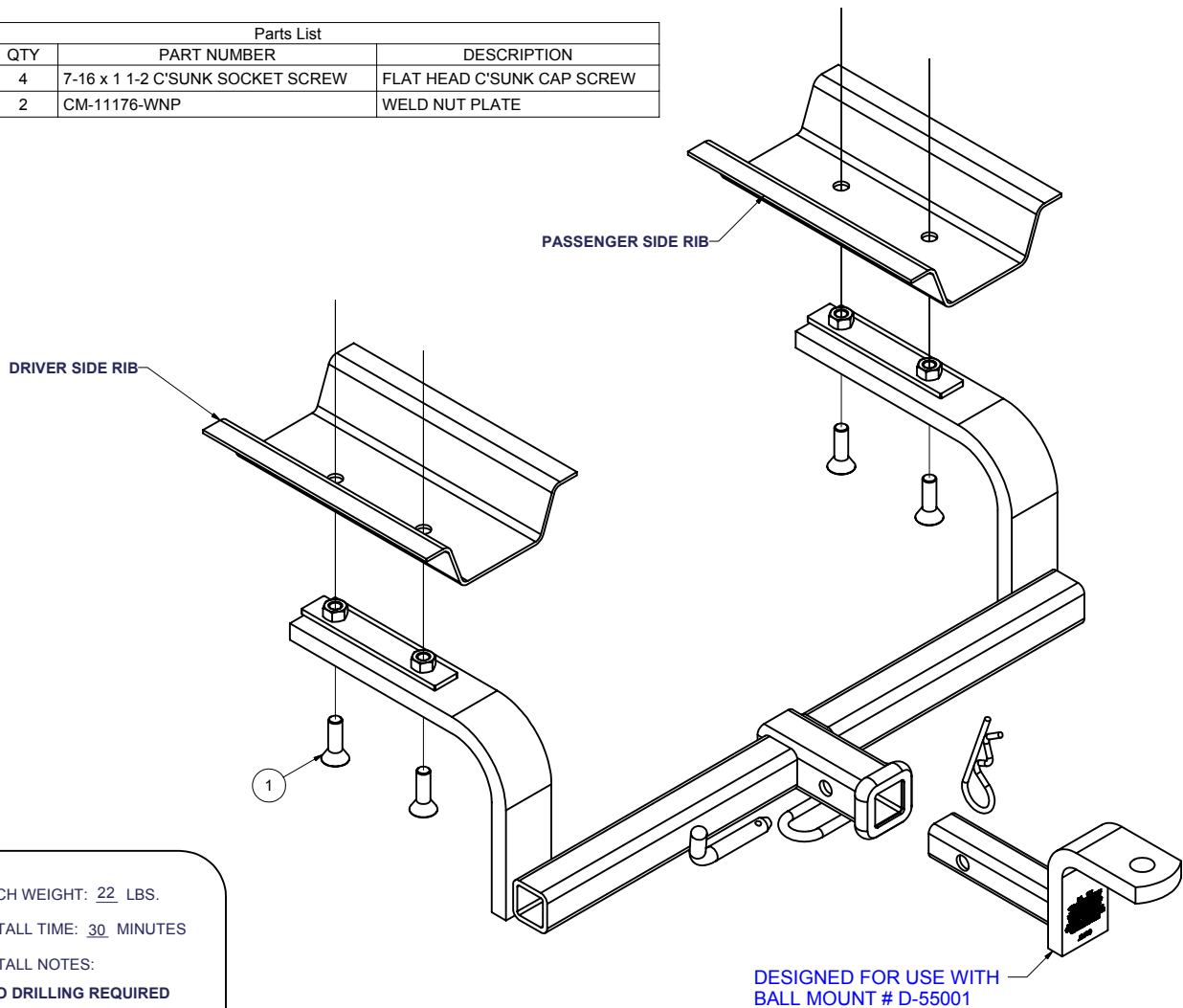

HITCH WEIGHT: 22 LBS.
INSTALL TIME: 30 MINUTES
INSTALL NOTES:
- NO DRILLING REQUIRED

INSTALLATION STEPS

- 1) This hitch mounts to the left and right ribs; 1 1/2" wide; running fore/aft. One rib is located over the spare tire well, and the other is located over the muffler (above the heat shield) at existing holes in ribs. Flat head socket screws are used for maximum clearance. A 1/4" hex socket drive tool will be necessary to tighten these screws.
- 2) Lower the spare tire and exhaust muffler temporarily.
- 3) Cut away a 1 1/2" wide x 6 1/2" long piece of the heat shield at the bottom of the right side rib for hitch bracket to fit directly onto the rib.
- 4) Place one nut plate into each rib from the rear aligning the nuts with the two rearmost holes in the rib.
- 5) Lift the hitch into position under the ribs aligning the holes and nuts and secure with fasteners as shown.
- 6) Torque all fasteners to 50 lb-ft using socket wrench driven 1/4" hex Allen hex tool.

PERIODICALLY CHECK THIS RECEIVER HITCH TO ENSURE THAT ALL FASTENERS ARE TIGHT AND THAT ALL STRUCTURAL COMPONENTS ARE SOUND.

Curt Manufacturing Inc., warrants this product to be free of defects in material and/or workmanship at the time of retail purchase by the original purchaser. If the product is found to be defective, Curt Manufacturing Inc., may repair or replace the product, at their option, when the product is returned, prepaid, with proof of purchase. Alteration to, misuse of, or improper installation of this product voids the warranty. Curt Manufacturing Inc.'s liability is limited to repair or replacement of products found to be defective, and specifically excludes liability for incidental or consequential loss or damage.